

M. BERGER.
REVOLVING SLIDE REST.

(Application filed May 24, 1898.)

(No Model.)

5 Sheets—Sheet 1.

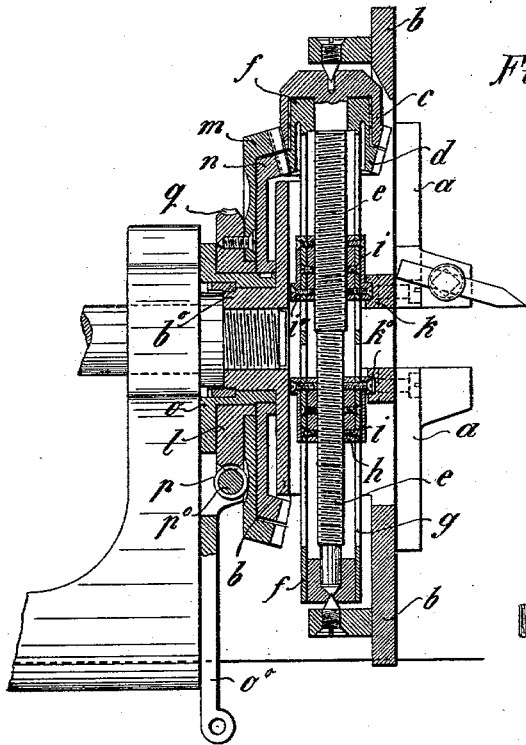

Fig. 1.

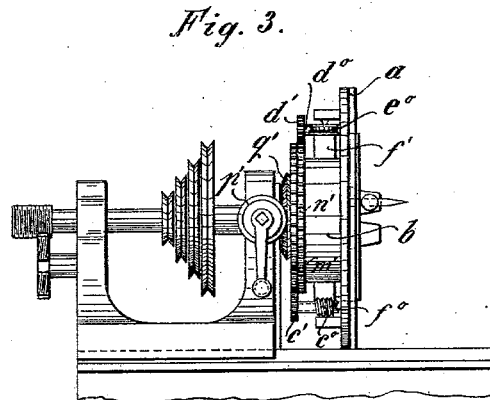

Fig. 3.

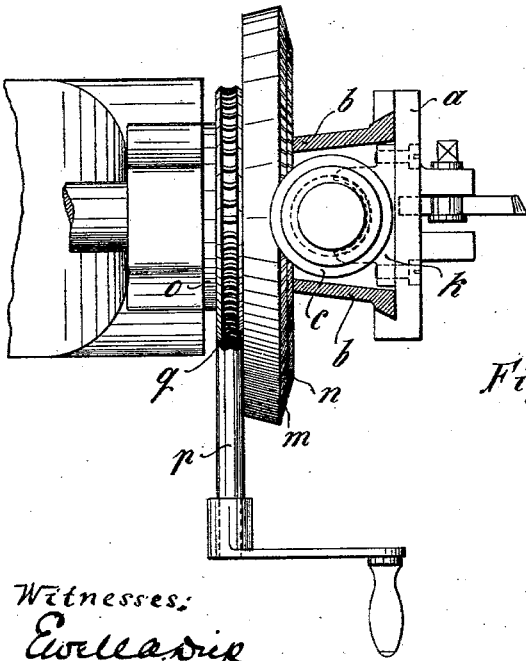

Fig. 2.

Witnesses:

Eveland

Alvin Talbot

Inventor:

Max Berger

*by Maxwell Deily
his atty.*

M. BERGER.
REVOLVING SLIDE REST.
(Application filed May 24, 1898.)

(No Model.)

5 Sheets—Sheet 2.

Fig. 3^a

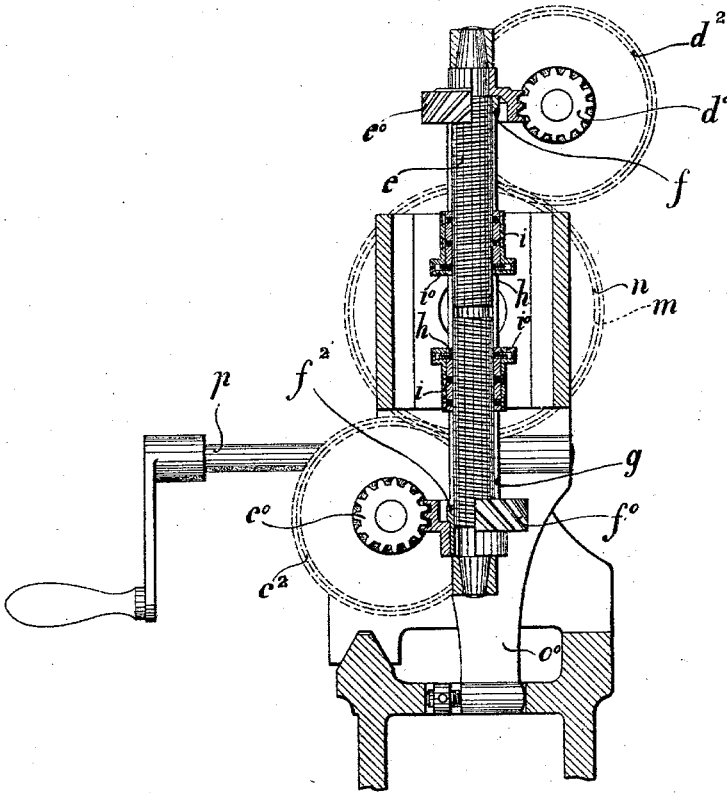

Witnesses:

Evelyn Dix

J. Hume Talbot

Inventor:

Max Berger

by Maxwell Daily
his atty.

M. BERGER.
REVOLVING SLIDE REST.

(Application filed May 24, 1898.)

(No Model.)

5 Sheets—Sheet 3.

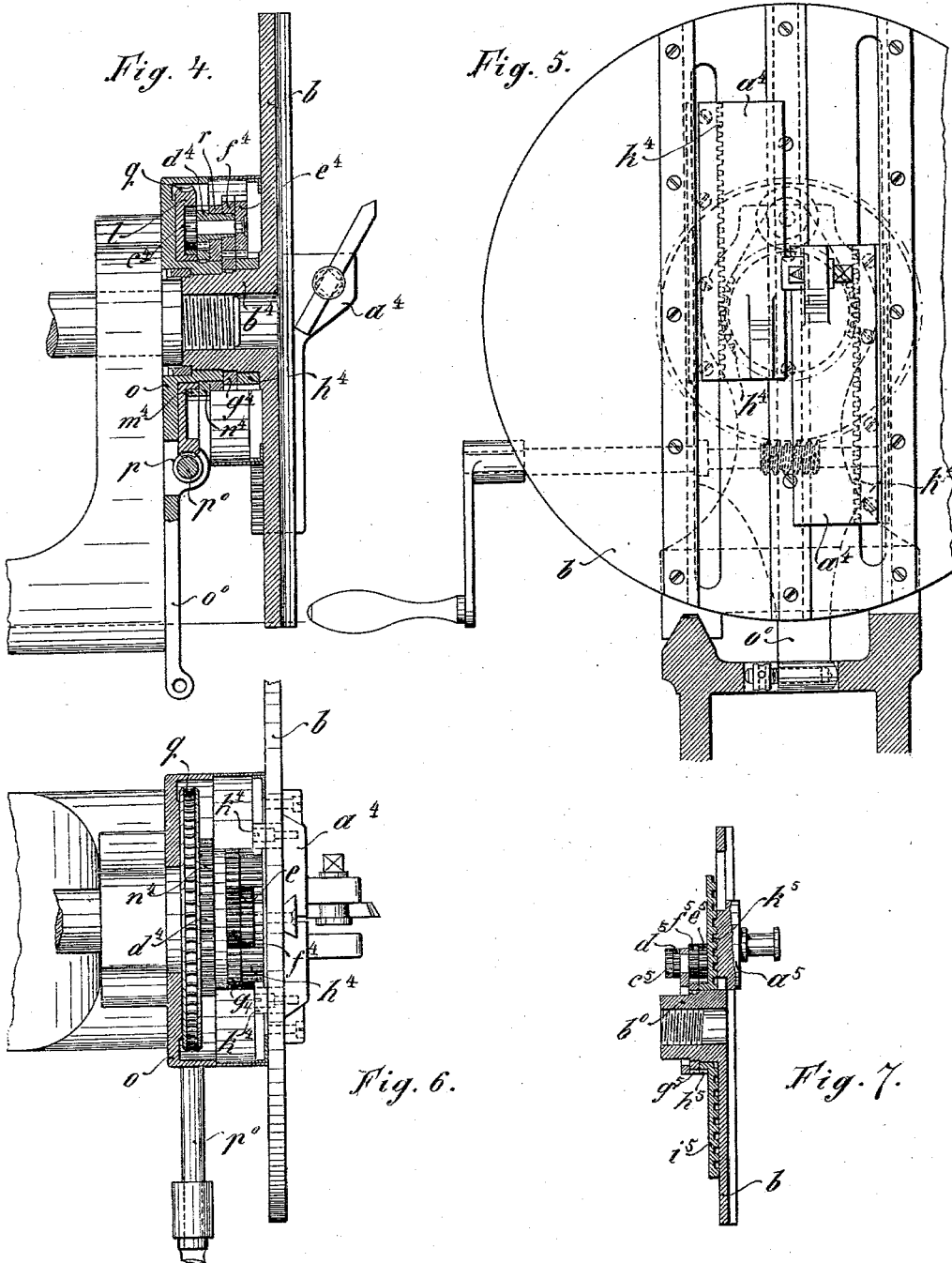

Witnesses:
E. W. L. A. S. P.
R. H. M. T. A. S.

Inventor:
 Max Berger
 by *Merrill Bailey*
 his atty

M. BERGER.
REVOLVING SLIDE REST.

(Application filed May 24, 1898.)

(No Model.)

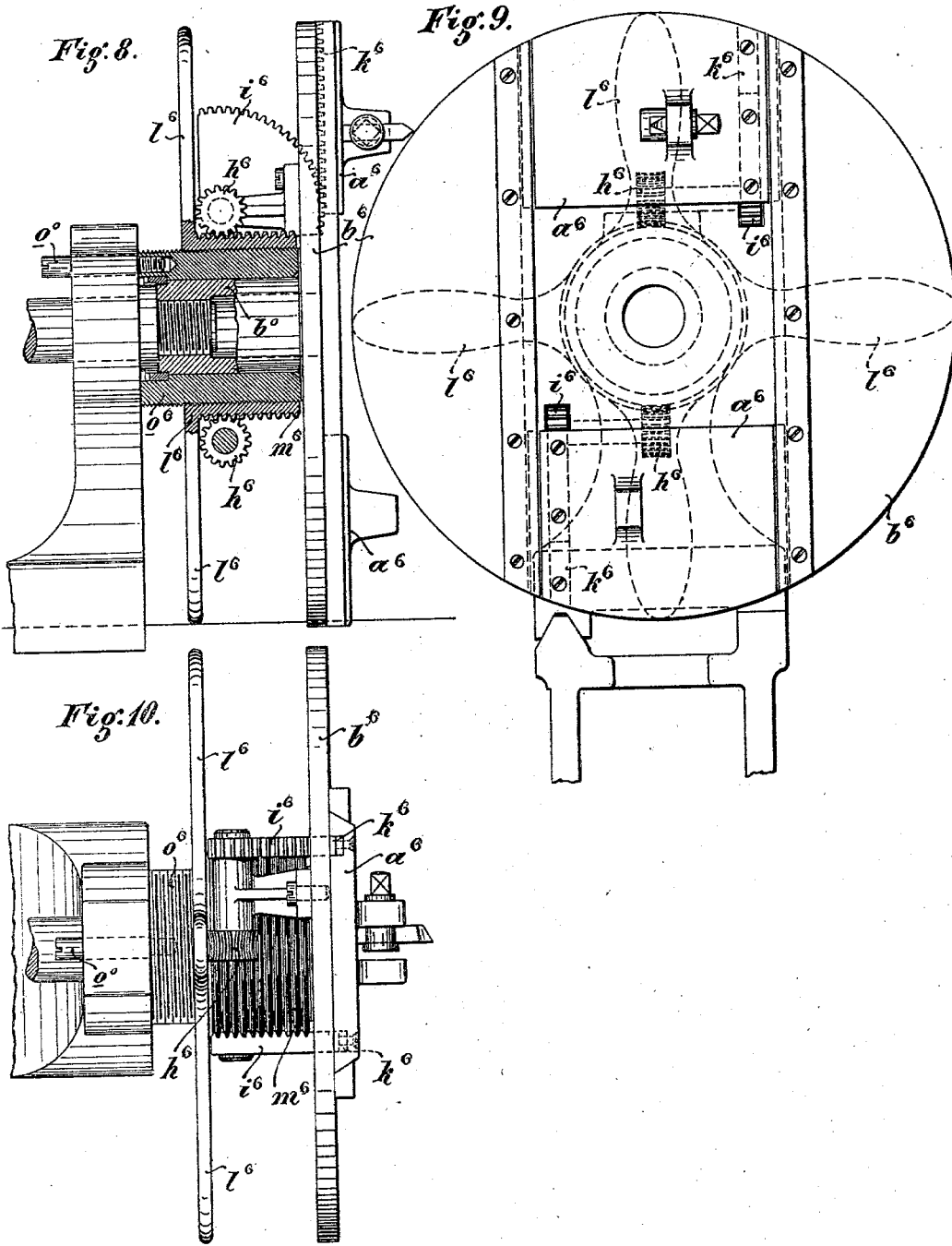

Witnesses:

E. W. C. S. S. S.

D. H. M. T. A. B. U. T.

Inventor:

Max Berger

Wm. S. S. S. S.
his atty.

M. BERGER.
REVOLVING SLIDE REST.

(No Model.)

Application filed May 24, 1898.

5 Sheets—Sheet 5.

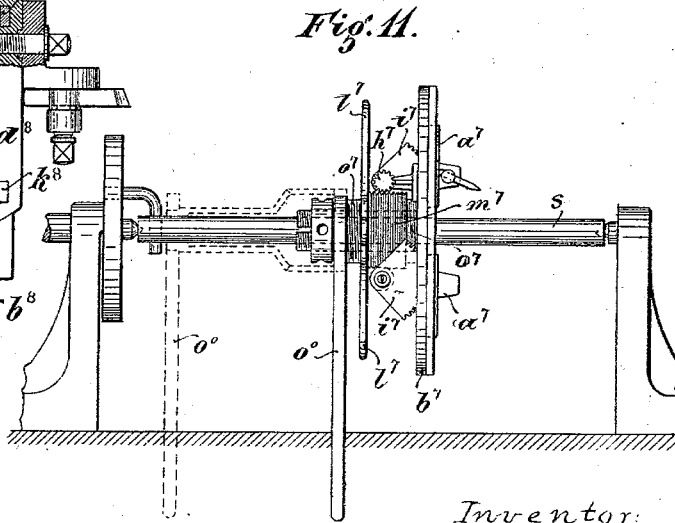
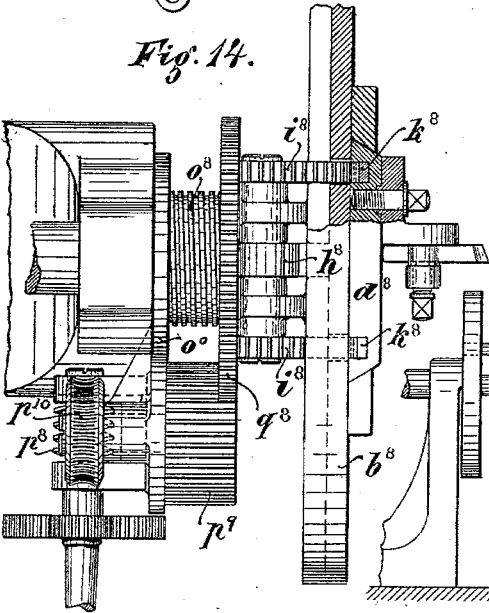
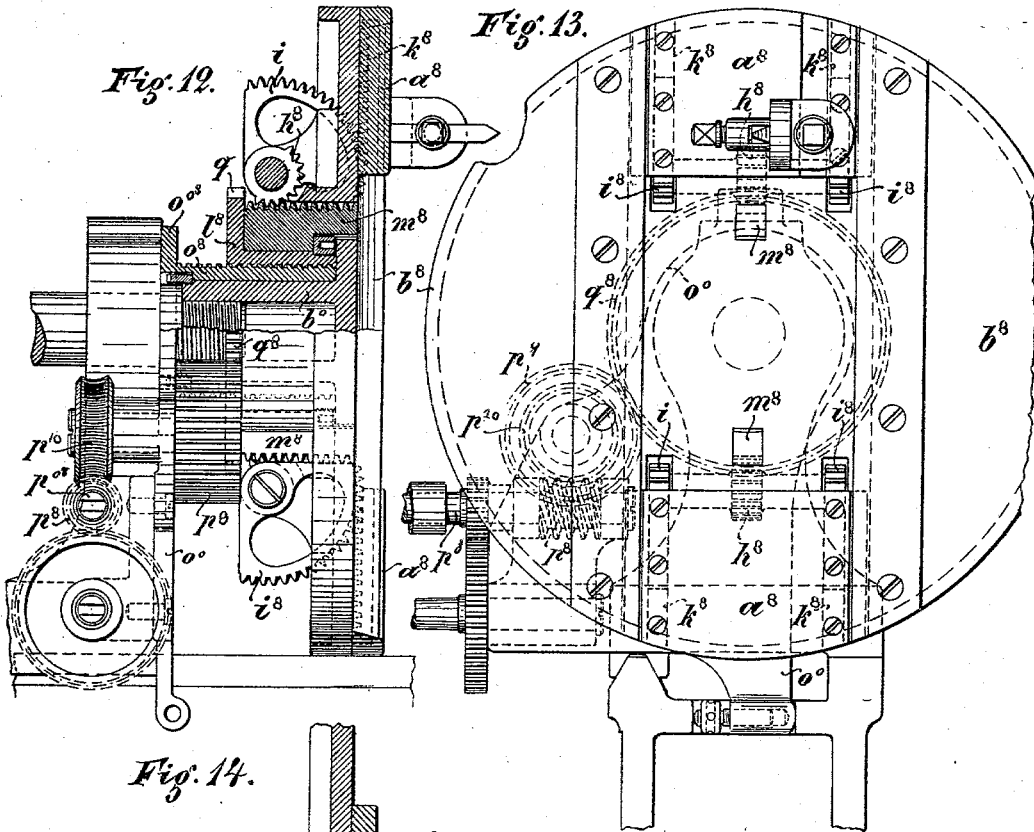

Witnesses:
E. W. ...
E. ...

Inventor:
Max Berger
by Marshall Daily his atty

UNITED STATES PATENT OFFICE.

MAX BERGER, OF JENA, GERMANY, ASSIGNOR TO THE FIRM OF CARL ZEISS,
OF SAME PLACE.

REVOLVING SLIDE-REST.

SPECIFICATION forming part of Letters Patent No. 632,230, dated September 5, 1899.

Application filed May 24, 1898. Serial No. 681,639. (No model.)

To all whom it may concern:

Be it known that I, MAX BERGER, a subject of the King of Saxony, residing at Jena, in the Grand Duchy of Saxe-Weimar, German Empire, have invented a new and useful Revolving Slide-Rest, (for which an application for patent has been filed in Germany on the 25th of October, 1897,) of which the following is a specification.

10 The object of this invention is to find a satisfactory solution of the problem to move at will a slide or slide-rest in the direction of its translatory motion while it revolves about an axis at right angles to this direction. An
15 arrangement enabling this result to be attained is applicable with advantage to a variety of technical purposes—for instance, where the carriage or slide supports a tool which might then while being revolved be
20 moved nearer to or farther from its axis of revolution. This, if the translatory movement of the tool-carrying slide be properly controlled, results in an arrangement for
25 plane-turning or "facing" with the work-piece simply secured on the bench or bed of the machine-tool, an arrangement the advantage whereof over that in which the tool is fastened to the plate is that it enables the tedious operations of centering, "truing,"
30 and balancing to be dispensed with. Among the other possible applications of such a contrivance the case of a slide carrying a crank-pin may be instanced, admitting of the stroke of the machine—say, a pump, a slotting or
35 planing machine, a cycle, &c.—being varied while the machine is in operation.

In adopting any of the means hitherto devised for solving the problem above stated it has been necessary in order to shift the slide
40 in either direction to retard or accelerate the rotary motion of a controlling-wheel, or the speed of either of two rotating controlling-wheels had to be reduced; but in neither case is it possible to impart to the slide a movement limited accurately at will or a constant
45 translatory movement standing in a predetermined relation to its number of revolutions. Now this important requirement is met by the present invention in the manner
50 hereinafter described.

With the operating mechanism mounted

upon the plate which carries the slide and serving to feed along such slide a controlling-wheel concentric with the axis of revolution of the slide-carrying plate is connected in
55 such a way that as long as it is prevented from turning the slide or carriage though it may revolve cannot at the same time receive a feeding or sliding movement from the said mechanism, whereas whenever the said
60 controlling-wheel is turned the slide will thereby be caused to travel along for a corresponding distance. It will be understood that the rotary movement of this controlling-wheel may
65 be exactly measured and regulated at will. To prevent the controlling-wheel from rotating with the plate while the slide is not required to be fed along, a screw or worm may
70 be fitted within the mechanism for operating the controlling-wheel, or a brake or locking device capable of being readily released may be provided, or it may suffice to insure adequate friction.

In the accompanying drawings, Figure 1 is an axial section of a slide-carrying plate constructed in accordance with this invention
75 and of which Fig. 2 is a plan. Fig. 3 is an elevation of a plate of a similar form of construction. Fig. 3^a is a transverse section of substantially the same plate as shown in Fig. 3, but having modified gearing means. Fig.
80 4 is an axial section showing a third form of construction of the device, Figs. 5 and 6 being respectively a front elevation and a plan thereof. Fig. 7 is an axial section of a similar
85 plate. Fig. 8 is an axial section of a fifth modification of the said plate, Fig. 9 being a front view, and Fig. 10 a plan, of such plate. Fig. 11 is a side view of a similar form of construction of the improved apparatus. Fig. 12
90 is an axial section of a seventh modification of the invention, while Fig. 13 is a corresponding front elevation, and Fig. 14 a plan, of the same.

In the several modifications represented in
95 the drawings certain parts which though different in outward appearance serve for fulfilling similar functions are designated by like letters of reference, but having different exponents in the different modifications illustrated.
100

With the exception of Fig. 7, which shows

a crank-disk, it is assumed that a face-plate fitted with a sliding tool-holder has to be dealt with and that such plate forms a self-contained device adapted to be screwed bodily onto the spindle of an existing lathe or of a shaping, undercutting, drilling, or like machine. When the said face-plate instead of being, as here shown, a removable and exchangeable piece is intended to form the main part of a machine-tool of novel type, this will afford increased convenience for the accommodation of the diverse parts of machinery. In the illustrations of the several forms of apparatus here given it is supposed that two slides are adapted to travel in opposite directions upon the same diameter of the plate, except in Fig. 7, where a single carriage is shown. It will be understood that the number of the slides may easily be increased with only structural modifications of the examples here given. The forms of construction which the drawings illustrate may be divided into two sets or groups, of which the one comprised in Figs. 1 to 7 will be described first. In all the arrangements belonging to this group there are provided two planet-wheels adapted to revolve at a like angular speed, whether they be mounted coaxially or whether their respective axes be placed at an invariable distance from each other, one of such wheels being in gear with a toothed rim, which forms part of the controlling-wheel and being connected with the slide in such a manner that by turning the controlling-wheel the slide may be fed along, while the other planet-wheel engages with a second toothed rim likewise concentric with the axis of the plate, but stationary and is so connected with the slide-carrying plate that such plate whenever it turns causes the said planet-wheel to revolve.

In the example shown in Figs. 1 and 2 two slides or carriages a are supposed to be mounted upon the same plate b . The two planet-wheels c and d are connected with the two slides by means of a spindle e , diametrically arranged on the back of the face-plate b , and by means of a bush f , coaxial with the said spindle, by the longitudinal slots g , of which bush the nuts h of the spindle e are guided. Over the bush f two sleeves i are passed, these being screwed or otherwise suitably secured to the nuts h . An annular collar i^0 , provided on each of the sleeves i , engages in the slot or groove h^0 of one of two blocks k , rigidly connected with the slides a , so that whenever the spindle e is rotated in relation to the bush f and the nuts h are displaced in consequence the slides a are thereby moved radially. The spindle e is by the planet bevel-wheel c geared with the bevel-wheel m , secured to the controlling-wheel l , while the bush f engages with the stationary toothed rim n through the medium of the planet bevel-wheel d . The dimensions of the wheels are so determined that while the controlling-wheel l is at rest the two planet-wheels

e and d , and also, consequently, the spindle e and bush f , turn about their common axis at an equal angular speed, so that the nuts h do not move radially, whereas they will begin so to move the moment a difference in the rotation of the wheels c and d is brought about by a rotary movement of the controlling-wheel l . The face-plate b is represented as being screwed onto the spindle of the lathe by means of its boss b^0 . The controlling-wheel l is mounted not directly upon the boss b^0 of the face-plate b , but upon a sleeve o , rotatable on such boss and fitted with an arm o^0 , engaging with the lathe-bed slot, such sleeve o at the same time carrying the stationary toothed rim n . In the arm o^0 a bearing is provided for the shaft p^0 , which shaft for operating the controlling-wheel l gears, by means of a worm p , into the teeth of the worm-wheel or rim q , forming part of the controlling-wheel l .

Fig. 3 represents a modification of the arrangement shown in Figs. 1 and 2, wherein the spindle e and bush f' instead of being operated by the planet-wheels c and d are operated by worm-wheels e^0 f^0 . The corresponding worms d^0 and c^0 , arranged diametrically opposite each other upon the face-plate, are rigidly connected with the planet-wheels d' c' . For the worm-gearing pairs of other gear-wheels adapted for crossing shafts—say helical wheels, as shown in Fig. 3^a—may be substituted. The controlling-wheel is here supposed to be driven not by a worm and worm-wheel, as in Figs. 1 and 2, but through bevel-wheels p' and q' , a lock or brake device controllable from the crank-handle being provided, but not shown, to secure the controlling-wheel in the position of rest.

In the form of apparatus represented in Figs. 4 to 6 the planet-wheel c^4 , gearing with the toothed rim m^4 of the controlling-wheel l , is arranged coaxially with and rotatably in relation to the planet-wheel d^4 , which has the same size as the planet-wheel c^4 and gears with the stationary toothed rim h^4 . The shaft of the planet-wheels c^4 and d^4 has its bearings in an arm r , revoluble on the boss b^4 of the face-plate. To turn this arm, a spur-wheel f^4 , rigidly connected to the planet-wheel d^4 , but of larger size, gears with a toothed rim g^4 , secured to the boss b^4 of the plate b . A spur-wheel e^4 of the same size as the wheel f^4 is rigidly connected to the planet-wheel c^4 and gears with a toothed rim h^4 , loosely mounted upon the boss b^4 of the face-plate. The said wheels have such proportions that the spur-wheel e^4 imparts to the toothed rim h^4 while the controlling-wheel l remains at rest a rotary movement, which both as regards direction and angular speed is identical with that performed by the plate b . Each rotary movement of the controlling-wheel, however, will result in making the toothed rim h^4 either lag behind or take the lead of the said plate b , and consequently will involve a translatory

movement of the two slides a^4 , the racks k^4 of which gear with the toothed rim h^4 .

Fig. 7 shows a form of plate differing from the plate just described in that the rim h^5 instead of engaging a rack secured to the slide is rigidly connected to a spirally-grooved disk i^5 , with the thread of which engage the teeth h^5 of the slide a^5 .

Another typical form in which this invention may be carried out is exemplified by Figs. 8 to 10, 11, and 12 to 14. In the arrangements of this class the controlling-wheel cannot be mounted directly upon the boss of the face-plate, as it would have been feasible in the first group of examples, but must necessarily be carried by a sleeve, which is prevented from turning with the said face-plate. Upon this sleeve the controlling-wheel is fitted by means of a screw-thread, so that with its rotary motion an axial displacement is connected, which may be made serviceable in a variety of ways for feeding along the slide. In the example shown in Figs. 8 to 10 this result is attained by giving the boss of the controlling-wheel 7^6 the shape of a cylindrical rack m^6 , the pinions h^6 , which are in gear therewith and are supported by the face-plate, being each mounted upon a shaft which also carries a toothed sector i^6 , engaging with the rack k^6 of one of the slides a^6 . The sleeve o^6 in the example here represented is supposed to be retained in place, not, as in the arrangements previously described, by an arm engaging with the slot of the lathe, but by a screw, mounted in the head-stock of the lathe. The controlling-wheel 7^6 has no special driving mechanism provided for it, but is fitted with handles, it being assumed that its screw-thread fits that of the sleeve o^6 tightly enough to prevent the said controlling-wheel when the toothed wheels h^6 turn from being carried around with them owing to their frictional contact with the cylindrical rack m^6 .

Fig. 11 shows an arrangement which is substantially the same as that represented in Figs. 8 to 10, the only difference being that the face-plate disk b^7 is not screwed upon the spindle or mandrel of the lathe, but is clamped onto a boring-rod s , while the sleeve o^7 , as in the first group of examples, is retained in position by the arm o^7 .

In the arrangement shown in Figs. 12 to 14 there are substituted for the cylindrical rack m^7 of the last preceding example separate racks m^8 , guided in slots of the face-plate b^8 and coupled with the controlling-wheel, so as to follow the axial movement of this wheel. Instead of with handles the controlling-wheel is provided with a special operating mechanism, consisting of a toothed rim q^8 , which instead of gearing with a worm p^8 direct gears with a spur-wheel p^9 , rigidly connected with the worm-wheel p^{10} .

What I claim, and desire to secure by Letters Patent of the United States, is—

1. The combination with a slide adapted to revolve about an axis perpendicular to the

direction of the translatory movement of the slide, of a controlling-wheel mounted concentrically to the said axis, but so that it cannot be taken around by the revolving slide, means for rotating this wheel independently of the revolution of the slide, and mechanism connecting the controlling-wheel and the slide so as to cause the slide to travel in proportion to the rotation of the controlling-wheel, substantially as and for the purposes hereinbefore set forth.

2. The combination with a slide adapted to revolve about an axis perpendicular to the direction of the translatory movement of the slide, of a controlling-wheel mounted concentrically to the said axis, means for rotating this wheel independently of the revolution of the slide, a fixed toothed rim arranged concentrically to the same axis, another concentric toothed rim being part of the controlling-wheel, two planet-wheels engaging said rims and fitted to revolve with the slide, and means connecting the planet-wheel, which engages the rim of the controlling-wheel, with the slide so as to cause the slide to travel in proportion to the rotation of the controlling-wheel, essentially as and for the purpose set forth.

3. The combination with a slide adapted to revolve about an axis perpendicular to the direction of the translatory movement of the slide, of a controlling-wheel mounted concentrically to the said axis, means for rotating this wheel independently of the revolution of the slide, a fixed toothed rim arranged concentrically to the same axis, another concentric toothed rim on the controlling-wheel, two planet-wheels engaging said rims and fitted to revolve with the slide, a rotatable screw connected with one of the planet-wheels, a rotatable sleeve concentric to the said screw and connected with the other planet-wheel, and a nut on the said screw guided in slots of the said sleeve and engaging the slide, essentially as and for the purpose set forth.

4. The combination with a slide adapted to revolve about an axis perpendicular to the direction of the translatory movement of the slide, of a controlling-wheel mounted concentrically to the said axis, means for rotating this wheel independently of the revolution of the slide, a fixed beveled toothed rim arranged concentrically to the same axis, another concentric beveled toothed rim on the controlling-wheel, a rotatable screw carrying a beveled planet-wheel which engages one of the rims, a rotatable sleeve concentric to the said screw and carrying another beveled planet-wheel which engages the second rim, and a nut on the said screw guided in slots of the said sleeve and engaging the slide, essentially as and for the purpose set forth.

5. The combination with a slide adapted to revolve about an axis perpendicular to the direction of the translatory movement of the slide, of a controlling-wheel mounted concentrically to the said axis, means for rotating this wheel independently of the revolution of

the slide, a fixed toothed rim arranged concentrically to the same axis, another concentric toothed rim on the controlling-wheel, two planet spur-wheels engaging said rims, a rotatable screw, a rotatable sleeve concentric to the said screw, gearings connecting the screw with one planet spur-wheel and the sleeve with the other planet spur-wheel, and a nut on the said screw guided in slots of the said sleeve and engaging the slide, essentially as and for the purpose set forth.

6. The combination with a slide adapted to revolve about an axis perpendicular to the direction of the translatory movement of the slide, of a controlling-wheel mounted concentrically to the said axis, means for rotating this wheel independently of the revolution of the slide, a fixed toothed rim arranged concentrically to the same axis, another concentric toothed rim on the controlling-wheel, two planet spur-wheels engaging said rims, a rotatable screw, a rotatable sleeve concentric to the said screw, a helical wheel on the said screw engaging with a helical wheel on the shaft of one of the planet-wheels, a helical wheel on the said sleeve engaging with a helical wheel on the shaft of the other planet-wheel, and a nut on the screw guided in slots of the sleeve and engaging the slide, essentially as and for the purpose set forth.

7. The combination with a slide adapted to revolve about an axis perpendicular to the direction of the translatory movement of the slide, of a controlling-wheel mounted concentrically to the said axis, means for rotating this wheel independently of the revolution of the slide, a fixed toothed rim arranged concentrically to the same axis, another concentric toothed rim of the controlling-wheel, two planet spur-wheels engaging said rims, a third concentric toothed rim mounted to rotate with the angular speed of the revolving slide and engaging a spur-wheel which is rigidly connected with the planet-wheel gearing with the fixed rim, a fourth concentric toothed rim loosely mounted and engaging a spur-wheel which is rigidly connected with the planet-wheel gearing with the rim of the controlling-wheel, and a gearing connecting the fourth rim with the slide, essentially as and for the purpose set forth.

8. The combination with a slide adapted to revolve about an axis perpendicular to the direction of the translatory movement of the slide, of a controlling-wheel mounted concentrically to the said axis, means for rotating this wheel independently of the revolution of the slide, a fixed toothed rim arranged concentrically to the same axis, another concentric toothed rim on the controlling-wheel, two planet spur-wheels engaging said rims, a third concentric toothed rim mounted to rotate with the angular speed of the revolving slide and

engaging a spur-wheel, which is rigidly connected with the planet-wheel gearing with the fixed rim, a fourth concentric toothed rim loosely mounted and engaging a spur-wheel which is rigidly connected with the planet-wheel gearing with the rim of the controlling-wheel, and a rack fixed to the slide and engaging the teeth of the fourth rim, essentially as and for the purpose set forth.

9. The combination with a slide adapted to revolve about an axis perpendicular to the direction of the translatory movement of the slide, of a controlling-wheel mounted concentrically to the said axis, means for rotating this wheel independently of the revolution of the slide, a fixed toothed rim arranged concentrically to the same axis, another concentric toothed rim on the controlling-wheel, two planet spur-wheels engaging said rims, a third concentric toothed rim mounted to rotate with the angular speed of the revolving slide and engaging a spur-wheel, which is rigidly connected with the planet-wheel gearing with the fixed rim, a fourth concentric toothed rim loosely mounted and engaging a spur-wheel which is rigidly connected with the planet-wheel gearing with the rim of the controlling-wheel, and a rack fixed to the slide and engaging a spirally-grooved disk secured to the fourth rim, essentially as and for the purpose set forth.

10. The combination with a slide adapted to revolve about an axis perpendicular to the direction of the translatory movement of the slide, of a controlling-wheel mounted concentrically to the said axis on a fixed sleeve by means of a screw-thread, means for rotating this wheel independently of the revolution of the slide, a rack connected with the controlling-wheel so as to follow the axial displacement of this wheel, and a pinion engaging the said rack and geared with another rack fixed to the slide, essentially as and for the purpose set forth.

11. The combination with a slide adapted to revolve about an axis perpendicular to the direction of the translatory movement of the slide, of a controlling-wheel mounted concentrically to the said axis on a fixed sleeve by means of a screw-thread, means for rotating this wheel independently of the revolution of the slide, a cylindrical rack concentrically secured to the controlling-wheel, and a pinion engaging the said rack and geared with another rack fixed to the slide, essentially as and for the purpose set forth.

In testimony that I claim the foregoing as my invention I have signed my name in presence of two subscribing witnesses.

MAX BERGER.

Witnesses:

RUDOLPH FRICKE,
OSCAR PITZSCHLER.